

WIRE WOUND CHIP INDUCTORS SWI1008HQ SERIES

INTRODUCTION

The SWI series are wire wound chip inductors widely used in the communication applications such as cellular phones, cable modem, ADSL, repeaters, Bluetooth, and other electronic devices. The wire wound inductors advance in higher self resonate frequency, better Q factor, and much more stable performance. The HQ type offer higher Q factor and the current handling has also been improved with significantly lower DCR value. Precious tolerance of 2% is available.

FEATURES

- * Operating temperature -40 to +125 °C for ceramic series.
- * Excellent solderability and resistance to soldering heat .
- * Suitable for reflow soldering.
- * High reliability and easy surface mount assembly.
- * Wide range of inductance values are available for flexible needs.

PART NUMBER

SWI 1008 HQ 12N G - □□

1 2 3 4 5 Internal Code

1 Product Type

2 Chip Dimension

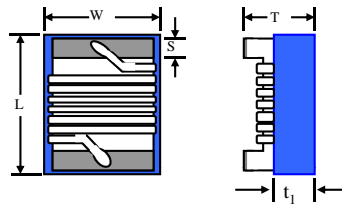

Size (inch) mm	Length (L) (inch) mm	Width (W) (inch) mm	Thickness (T) (inch) mm	Terminal (S) (inch) mm	(t ₁) (Ref.) mm
SWI 1008 2520	(0.098 ± 0.008) 2.60 ± 0.20	(0.080 ± 0.008) 2.10 ± 0.20	(0.063 ± 0.008) 1.70 ± 0.20	(0.020 ± 0.004) 0.50 ± 0.10	0.70

3 Material Type

HQ : High Q type

4 Inductance Value

10N = 10 nH
R10 = 100 nH

5 Tolerance

G = ± 2 %
J = ± 5 %
K = ± 10 %

CHIP INDUCTOR SPECIFICATIONS

1 Scope

This specification applies to fixed inductors of the following types used in electronic equipment :

*HQ Type : For lower inductance with high Q factor at high frequency and stable circuit requirement.

2 Construction

*Configuration & Dimension : Please refer to the attached figures and tables.

*Terminals : SWI series terminals shall consist of MoMn alloy or Ag followed by Nickel then Au plating for easier soldering.

3 Operating Temperature Range

Operating Temperature Range is the scope of ambient temperature at which the inductor can be operated continuously at rated current.

Temp. Range : Ceramic Material : - 40°C to + 125°C

4 Ingredient of terminals electrode.

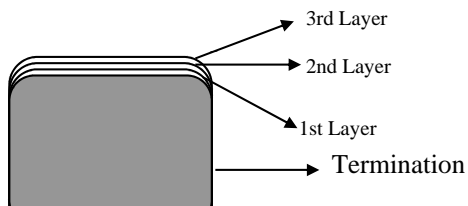

Ceramic Type

- a) 1st layer : Mo/Mn or Ag
- b) 2nd layer : Nickel
- c) 3rd layer : Gold

5 Characteristics

Standard Atmospheric Conditions

Unless otherwise specified, the standard range of atmospheric conditions for making measurements and tests are as follows :

Ambient Temperature : 25 °C ± 2 °C

Relative Humidity : 60% to 70%

Air Pressure : 86 Kpa to 106 Kpa

CHIP INDUCTOR SPECIFICATIONS

TEMPERATURE PROFILE

- a** Reflow temperature profile
(Temperature of the mounted parts surface on the printed circuit board)

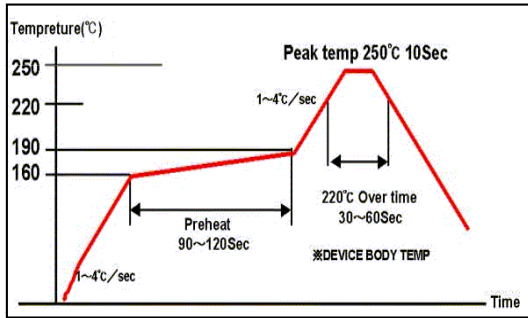

Recommended Peak Temperature: 250°C Max
 250°C up /within 10secs
 Max. Reflow temperature : 260°C.
 Gradient of temperature rise: av 1-4°C/sec
 Preheat: 160-190°C/within 90-120secs
 220°C up /within 30-60secs
 Composition of solder Sn-3Ag-0.5Cu

- b** Dip temperature

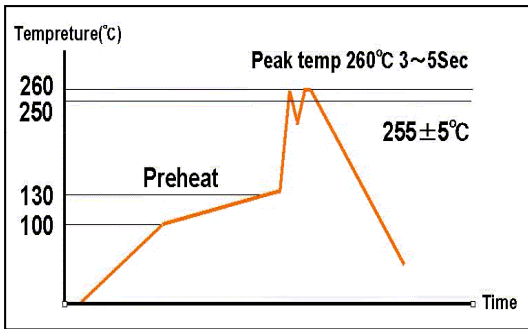

Solder bathtub temperature: 260°C max
 within 5secs.
 Preheating temperature: 100~130°C
 deposit solder temperature.
 Composition of solder Sn-3Ag-0.5Cu

- c** Soldering iron tip temperature : 350°C max / within 3 seconds.

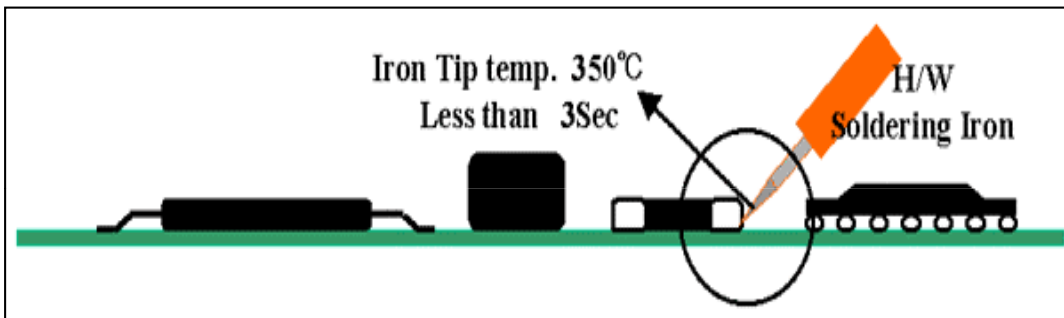

WIRE WOUND CHIP INDUCTOR

SWI1008HQ SERIES

Part No.	Inductance ¹ (nH)	Percent Tolerance	Q ² Min	S.R.F. ³ Min (MHz)	RDC ⁴ Max (Ω)	IDC ⁵ Max (mA)	Marking
SWI 1008 HQ 3N0 □-□□	3.0 @ 50 MHz	J, K	70 @ 1500MHz	8100	0.04	1600	3N0
SWI 1008 HQ 7N8 □-□□	7.8 @ 50 MHz	J, K	75 @ 1500MHz	3800	0.05	1600	7N8
SWI 1008 HQ 10N □-□□	10 @ 50 MHz	J, K	60 @ 500MHz	3600	0.08	1300	10N
SWI 1008 HQ 12N □-□□	12 @ 50 MHz	G, J, K	70 @ 500MHz	2800	0.06	1500	12N
SWI 1008 HQ 18N □-□□	18 @ 50 MHz	G, J, K	62 @ 350MHz	2700	0.08	1400	18N
SWI 1008 HQ 22N □-□□	22 @ 50 MHz	G, J, K	62 @ 350MHz	2050	0.07	1400	22N
SWI 1008 HQ 33N □-□□	33 @ 50 MHz	G, J, K	75 @ 350MHz	1700	0.09	1300	33N
SWI 1008 HQ 39N □-□□	39 @ 50 MHz	G, J, K	75 @ 350MHz	1300	0.09	1300	39N
SWI 1008 HQ 47N □-□□	47 @ 50 MHz	G, J, K	75 @ 350MHz	1450	0.12	1200	47N
SWI 1008 HQ 56N □-□□	56 @ 50 MHz	G, J, K	75 @ 350MHz	1230	0.12	1200	56N
SWI 1008 HQ 68N □-□□	68 @ 50 MHz	G, J, K	80 @ 350MHz	1150	0.13	1000	68N
SWI 1008 HQ 82N □-□□	82 @ 50 MHz	G, J, K	80 @ 350MHz	1060	0.16	1000	82N
SWI 1008 HQ R10 □-□□	100 @ 50 MHz	G, J, K	62 @ 350MHz	820	0.16	1000	R10

1. Inductance is measured in HP-4287A RF LCR meter with HP-16193 fixture.
2. Q is measured in HP-4287A RF LCR meter with HP-16193 fixture.

3. SRF is measured in ENA E5071B network analyzer
4. RDC is measured in HP-4338B milliohmmeter.
5. For 15 °C Rise.
Unit weight = 0.025g (for ref.)

SWI 1008HQ (2520) CERAMIC SERIES

L vs Freq Plot

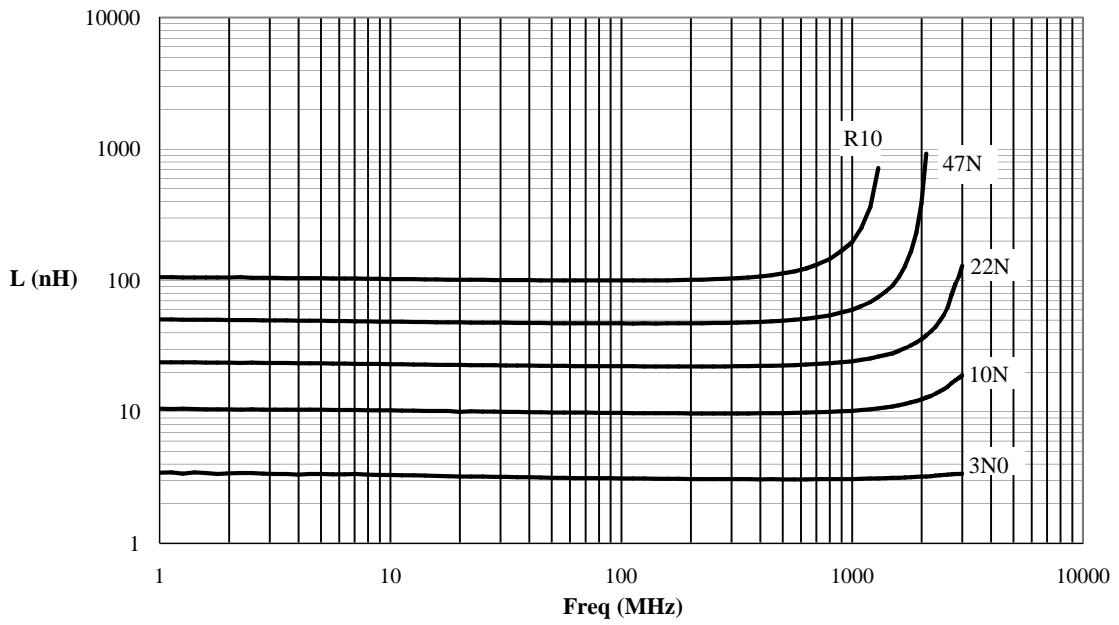

Q vs Freq Plot

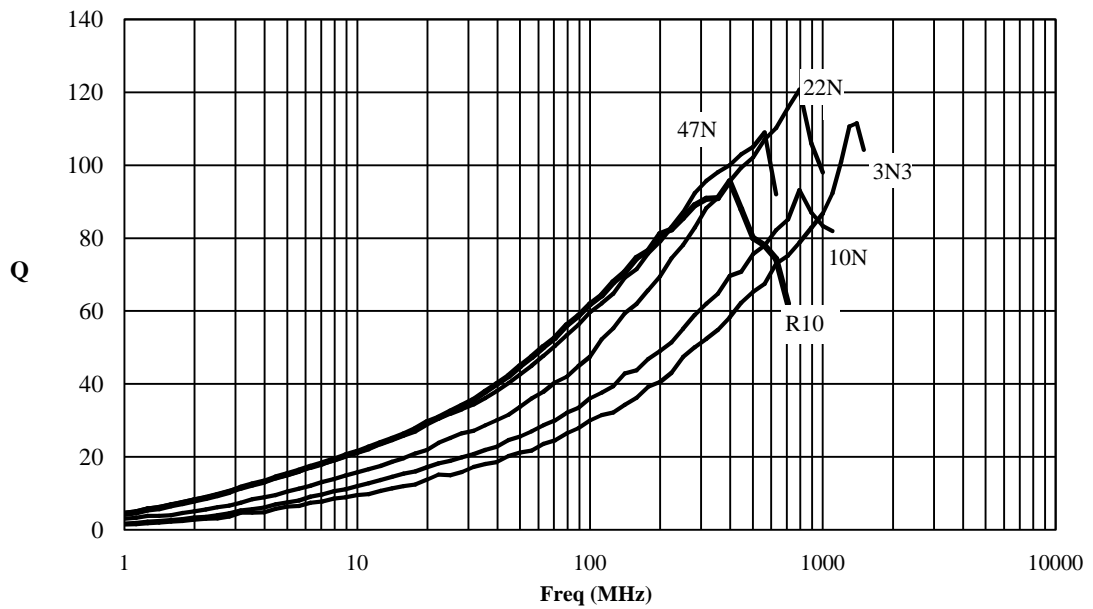

SPECIFICATION

	ITEM	CONDITION	SPECIFICATION
Mechanical Characteristics	Inductance and Tolerance	Measuring Frequency : As shown in Product Table	Within Specified Tolerance
	Quality Factor	Measuring Temperature : + 25 °C	
	Insulation Resistance	Measured at 100V DC between inductor terminals and center of case.	1000 mega ohms minimum
	Dielectric Withstanding Voltage	Measured at 500V AC between inductor terminals and center of case for a maximum of 1 minute.	No damage occurs when the test voltage is applied.
	Temperature Coefficient of Inductance (TCL)	Over - 40 °C to + 85°C at frequency specified in Product Table.	+ 25 to 500 ppm / °C $TCL = \frac{L1 - L2}{L1(T1-T2)} \times 10^6$ (ppm /°C)
	Electrical Characteristics	Component Adhesion (Push Test)	The component shall be reflow soldered onto a P. C. Board (240 °C ± 5°C for 20 seconds). Then a dynameter force gauge shall be applied to any side of the component.
Drop Test		The inductor shall be dropped two times on the concrete floor or the vinyl tile from 1M naturally.	Change In Inductance: No more than 5%
Thermal Shock Test		Each cycle shall consist of 30 minutes at -40 °C followed by 30 minutes at +85 °C with a 20-second maximum transition time between temperature extremes. Test duration is 10 cycles.	Change In Q: No more than 10% Change In Appearance: Without distinct damage

SPECIFICATION

	ITEM	CONDITION	SPECIFICATION
Endurance Characteristics	Solderability	Dip pads in flux and dip in solder pot containing lead free solder at $240\text{ }^{\circ}\text{C} \pm 5^{\circ}\text{C}$ for 5 seconds.	A minimum of 80% of the metalized area must be covered with solder.
	Resistance to Soldering Heat	Dip the components into flux and dip into solder pot containing lead free solder at $260\text{ }^{\circ}\text{C} \pm 5\text{ }^{\circ}\text{C}$ for 5 ± 2 seconds.	Change In Inductance: No more than 5%
	Vibration (Random)	Inductors shall be randomly vibrated at amplitude of 1.5mm and frequency of 10 - 55 Hz: 0.04 G / Hz for a minimum of 15 minutes per axis for each of the three axes.	Change In Q: No more than 10%
	Cold Temperature Storage	Inductors shall be stored at temperature of $-40\text{ }^{\circ}\text{C} \pm 2\text{ }^{\circ}\text{C}$ for 1000hrs (+ 48 -0 hrs.) Then inductors shall be subjected to standard atmospheric conditions for 1 hour. After that, measurement shall be made.	Change In Appearance : Without distinct damage
	High Temperature Storage	Inductors shall be stored at temperature of $85\text{ }^{\circ}\text{C} \pm 2\text{ }^{\circ}\text{C}$ for 1000hrs (+48 - 0hrs.) Then inductors shall be subjected to standard atmospheric conditions for 1 hour. After that, measurement shall be made.	
	Moisture Resistance	Inductors shall be stored in the chamber at $45\text{ }^{\circ}\text{C}$ at 90 - 95 R. H. for 1000 hours. Then inductors are to be tested after 2 hours at room temperature.	Inductors shall not have a shorted or open winding.
	High Temperature with Loaded	Inductors shall be stored in the chamber at $+85\text{ }^{\circ}\text{C}$ for 1000 hours with rated current applied. Inductors shall be tested at the beginning of test at 500 hours and 1000 hours. Then inductors are to be tested after 1 hour at room temperature.	

PACKAGING INFORMATION

Packing Quantity

Type	Pcs / Reel
SWI1008HQ	2,000

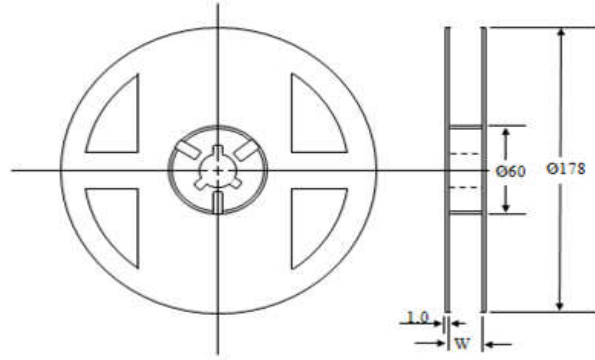

Dimensions (unit: m/m)

Type	Chip Cavity		Insert Pitch	Tape Thickness		
	A	B	F	K	T	W
SWI1008HQ	2.23	2.73	4.00	1.80	0.20	8.00

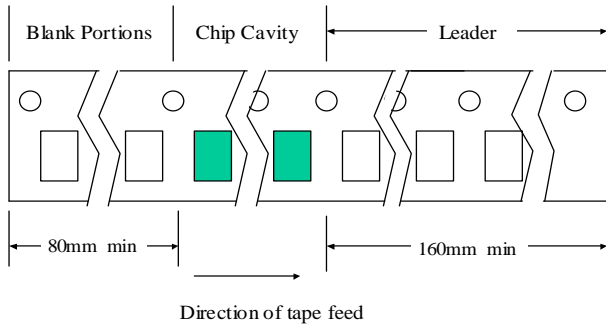
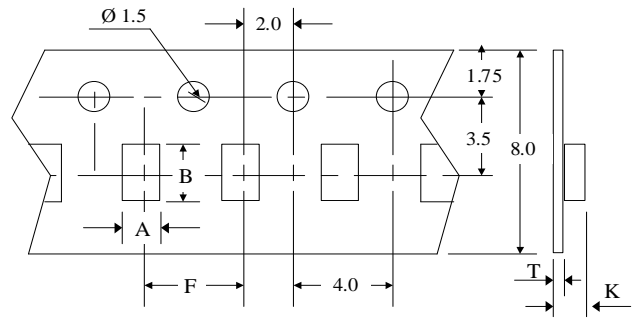

Top Tape Strength

The top tape requires a peel-off force of 0.2 to 0.7N in the direction of the arrow as illustrated below.

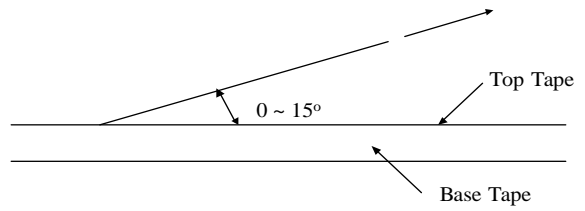

Dimensions (unit : m/m)

TYPE	A	B	C
SWI1008HQ	3.00	1.20	2.20

Recommended Pattern

