

CHIP COMMON MODE CHOKE COIL PWC SERIES

INTRODUCTION

This specification is applicable to chip type wire wounded common mode chokes. The PWC series are widely used in USB 2.0, IEEE 1394, LVDS and etc. The wire wound features advance in lower DC resistance and higher current tolerance, and much stable performance.

FEATURES

- * Operating temperature -40°C to +85°C
- * Excellent solderability and resistance to soldering heat.
- * Suitable for flow and reflow soldering.
- * Good dimensions, high reliability, and easy surface mount assembly.

PART NUMBER

PWC 0603 S T 900 S - □□

1 2 3 4 5 6 - Internal code

1 Chip Common Mode Choke Coil

2 Chip Size

CODE	L	W	H	UNIT
0603ST	1.60 ± 0.10	0.85 ± 0.10	1.10 ± 0.10	mm
0805HT	2.00 ± 0.20	1.20 ± 0.20	1.00 ± 0.20	mm
0805ST	2.00 ± 0.20	1.20 ± 0.20	1.20 ± 0.20	mm
1206ST	3.20 ± 0.20	1.60 ± 0.20	1.90 ± 0.20	mm

3 General Characteristics

4 Taped In Reel. 2,000pcs/reel.

5 Typical Impedance at 100MHz

900 = 90Ω

181 = 180Ω

222 = 2200Ω

6 Tolerance

S = ± 25%

MATERIAL STRUCTURE

a) PWC ST Series

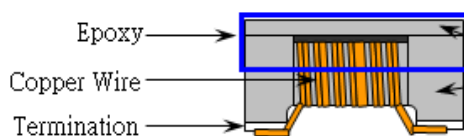

b) PWC HT Series

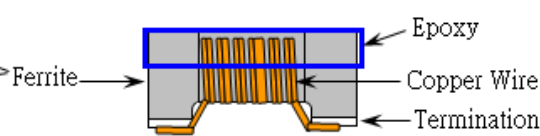

DIMENSION AND CONFIGURATION

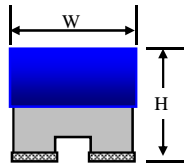
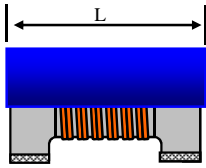

RECOMMENDED PCB PATTERN

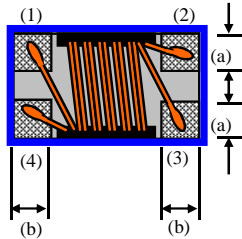
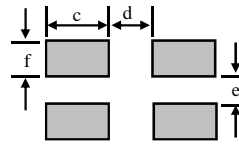

Remark : : Electrode
 () : Reference Value

EQUIVALENT CIRCUIT

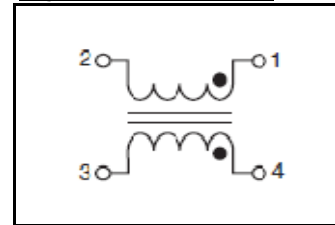

Code	L	W	H	a	b	c	d	e	f
0603ST	1.60 ± 0.10	0.85 ± 0.10	1.10 ± 0.10	0.25	0.33	0.85	0.60	0.25	0.25
0805HT	2.00 ± 0.20	1.20 ± 0.20	1.00 ± 0.20	0.40	0.45	0.90	0.80	0.40	0.40
0805ST	2.00 ± 0.20	1.20 ± 0.20	1.20 ± 0.20	0.40	0.45	0.90	0.80	0.40	0.40
1206ST	3.20 ± 0.20	1.60 ± 0.20	1.90 ± 0.20	0.60	0.60	1.00	1.60	0.40	0.60

Unit: mm

PWC 0805 HT SERIES

Part Number	Common Mode ¹ Impedance (Ω) at 100MHz	Rated Voltage V (DC)	Withstanding Voltage V (DC)	Rated ² Current max (mA)	DC Resistance max (Ω)	Insulation Resistance min (MΩ)
PWC0805HT670S	67	50	125	330	0.35	10
PWC0805HT900S	90	50	125	300	0.40	10
PWC0805HT121S	120	50	125	280	0.45	10
PWC0805HT181S	180	50	125	250	0.50	10

1. Impedance is measured in HP4287A at frequency of 100MHz.
2. For 15 °C rise.

PWC 0805HT (2012) SERIES

Z vs Freq Plot

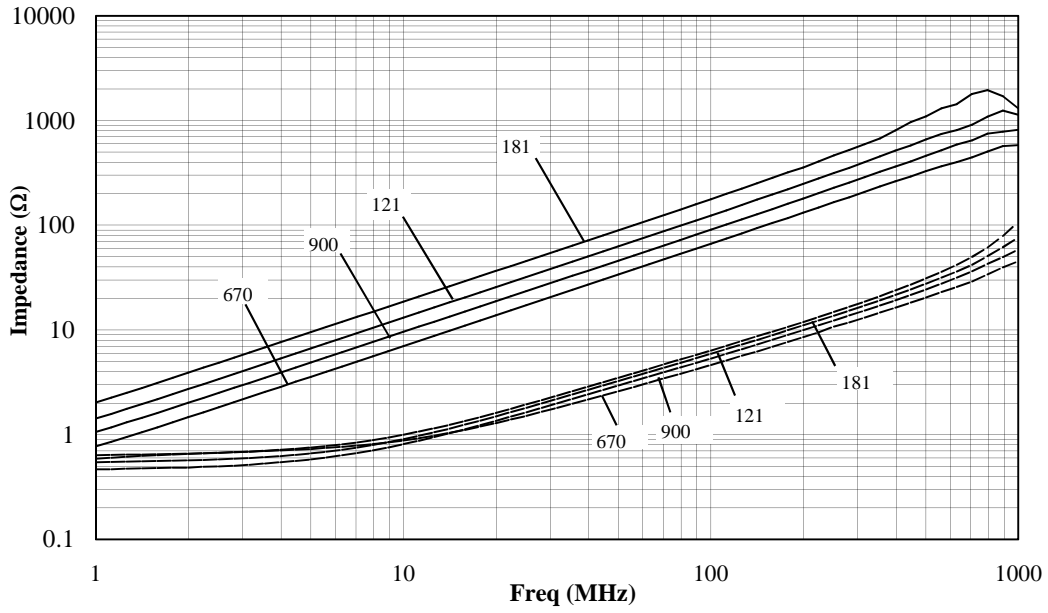

RELIABILITY SPECIFICATION

1 Scope

This specification applies to wired wounded chip common mode choke of the following types used in electronic equipment :

*Material : Ferrite

2 Construction

*Configuration

& Dimension: Please refer to the attached figures and tables.

*Terminals : PWC series shall consist of Ag followed by Nickel, then gold or tin plating.

3 Operating Temperature Range

Operating Temperature Range is the scope of ambient temperature at which the common mode choke can be operated continuously at rated current.

*Temp. Range: $-40\text{ }^{\circ}\text{C}$ to $+85\text{ }^{\circ}\text{C}$

4 Recommended Soldering Conditions

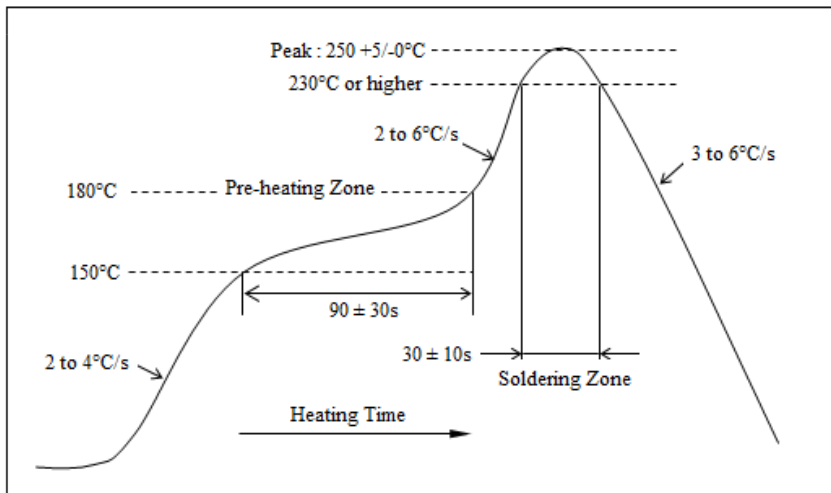

5 Characteristics

Standard Atmospheric Conditions

Unless otherwise specified, the standard range of atmospheric conditions for making measurements and tests are as follows :

*Ambient Temperature : $25\text{ }^{\circ}\text{C} \pm 2\text{ }^{\circ}\text{C}$

*Relative Humidity : 60% to 70% (RH)

*Air Pressure : 86 Kpa to 106 Kpa

RELIABILITY SPECIFICATION

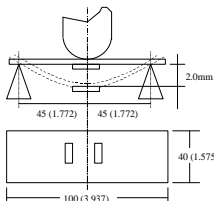
	ITEM	CONDITION	SPECIFICATION
Electrical Characteristics	Common Mode Impedance (Zc) and Tolerance	Measuring Equipment : HP-4287A or equivalent. Measuring Frequency : 100 ± 1MHz Measuring Temperature : 25 ± 5°C (Refer to Measurement Diagram)	Within ± 25%
	Insulation Resistance	Measuring Voltage : Rated Voltage Measuring Time : 1 minute max. (Refer to Measurement Diagram)	10 mega ohms minimum
	Dielectric Withstanding Voltage	Test Voltage : 2.5 times to Rated Voltage Time : 1 to 5 seconds. Charge current : 1mA max. (Refer to Measurement Diagram)	No damage occurs when the test voltage is applied.
	Rated Current	Test Current : Rated Current (Refer to Measurement Diagram)	Temperature Rise : ≤ 15°C
	DC Resistance (RDC)	Measured with current of 100mA max. In case of doubt, measured by four terminal method. (Refer to Measurement Diagram)	Within Specified Tolerance.
Mechanical Characteristics	Flexure Strength		Table 1. <div style="border: 1px solid black; padding: 5px;"> Change In Appearance: Without distinct damage Change In Common Mode Impedance: Within ± 20% Insulation Resistance: 10MΩ min Withstanding Voltage: No damaged </div>
	Drop Test	Components shall be dropped three times on a concrete or steel board at height of 1 M naturally at any directions.	
	Vibration (Random)	Components shall be randomly vibrated at amplitude of 1.5mm and frequency of 10 - 55 Hz: 0.04 G / Hz, 1 minute at a period of 2 hours in each of the three mutually perpendicular directions.	
	Solderability	Dip pads in flux and then in a solder bath at 240 °C ± 5°C for 5 seconds.	A minimum of 80% of the metalized area must be covered with new solder.
	Resistance to Soldering Heat	Preheat components at 80 to 120 °C for 1 minute. Dip components into flux and then into a melted solder bath at 260 ± 5°C for 5 ± 1 seconds. Then components are to be tested after 4-48 hours at room temperature.	Meet Table 1.
	Component Adhesion (Push Test)	Components shall be reflow solder onto a P. C. Board (240 ± 5°C for 20 seconds). Then a dynamometer force gauge shall be applied to any side of the component.	0603 : 0.5Kg minimum 0805 : 1.0Kg minimum 1206 : 1.0Kg minimum Without failure of termination to the component attachment.

RELIABILITY SPECIFICATION

	ITEM	CONDITION	SPECIFICATION
Endurance Characteristics	Cold Temperature Storage	Components shall be stored at temperature of $-40\text{ }^{\circ}\text{C} \pm 2\text{ }^{\circ}\text{C}$ for 1000 (+48 hours -0 hour). Then components shall be subjected to standard atmospheric conditions for 4-48 hours. After that, measurement shall be made.	Table 1. Change In Appearance: Without distinct damage
	High Temperature Storage	Components shall be stored at temperature of $+85\text{ }^{\circ}\text{C} \pm 2\text{ }^{\circ}\text{C}$ for 1000 (+48 hours -0 hour). Then components shall be subjected to standard atmospheric conditions for 4-48 hour. After that, measurement shall be made.	Change In Common Mode Impedance: Within $\pm 20\%$
	Moisture Resistance	Components shall be stored in the chamber at $40\text{ }^{\circ}\text{C}$ at 90 - 95% R. H. for 1000 (+48 hours -0 hour). Then components are to be tested after 4-48 hours at room temperature.	Insulation Resistance: $10\text{M}\Omega$ min
	Temperature Cycle	Each cycle shall consist of 30 minutes at $-40\text{ }^{\circ}\text{C}$ followed by 30 minutes at $85\text{ }^{\circ}\text{C}$ with a 10-15 minutes maximum transition time between temperature extremes. Test duration is 100 cycles, then components are to be tested after 4-48 hours at room temperature.	Withstanding Voltage: No damaged
	High Temperature With Loaded (Rated Current)	Components shall be stored at temperature of $+85\text{ }^{\circ}\text{C} \pm 2\text{ }^{\circ}\text{C}$ for 1000 (+48 hours -0 hour) with rated current applied. Then components shall be subjected to standard atmospheric conditions for 4-48 hour. After that, measurement shall be made.	

RELIABILITY SPECIFICATION

Measurement Diagram

Terminal to be Tested

When measuring and supplying the voltage, the following terminal is applied.

No.	Item	Terminal to be Tested
1	Common Mode Impedance (Measurement Terminal)	
2	Withstanding Voltage (Measurement Terminal)	
3	DC Resistance (Measurement Terminal)	
4	Rated Current	
5	Insulation Resistance	

PACKAGING INFORMATION

Packing Quantity

Type	Pcs / Reel
PWC0603ST	2,000
PWC0805HT	2,000
PWC0805ST	2,000
PWC1206ST	2,000

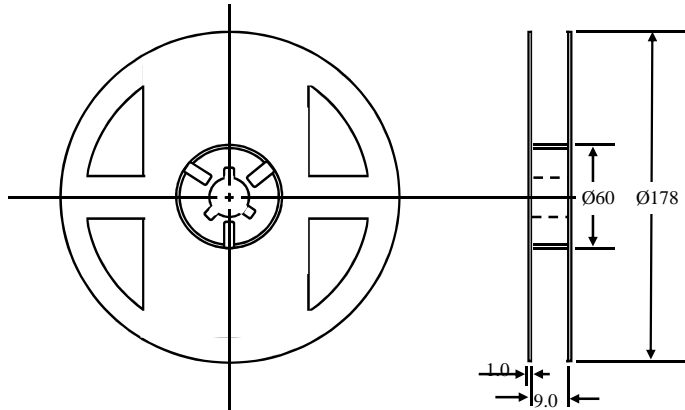

Dimensions (unit: m/m)

Type	Chip Cavity		Insert Pitch	Tape Thickness	
	A	B	F	K	T
Tolerance	± 0.10mm				
PWC0603ST	1.05	1.85	4.00	1.15	0.23
PWC0805HT	1.48	2.33	4.00	1.08	0.23
PWC0805ST	1.50	2.35	4.00	1.45	0.23
PWC1206ST	1.88	3.50	4.00	2.10	0.23

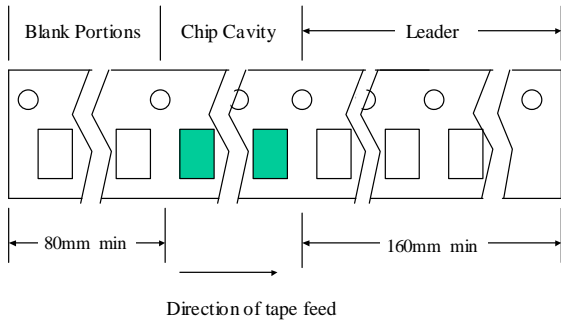
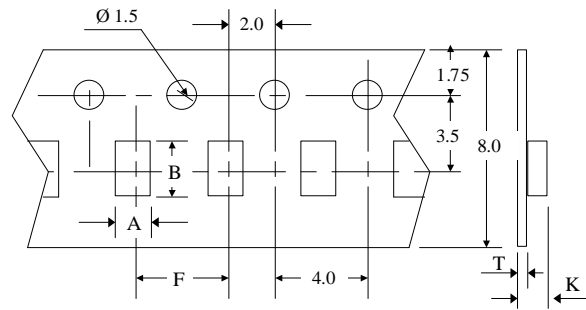

Top Tape Strength

The top tape requires a peel-off force of 0.2 to 0.7N in the direction of the arrow as illustrated below.

