

WIRE WOUND CHIP INDUCTORS LPI SERIES

INTRODUCTION

Product : LPI Miniature SMD Inductor For Power Line

Size : 0603 / 0805 / 1210

The LPI series are low profile inductor used in notebooks, PC, cellular phone backlight, inverter and etc.

The devices are designed smallest possible sizes and highest performance.

FEATURES

- * Operating temperature -40 to +85°C.
- * Excellent solderability and resistance to soldering heat .
- * Suitable for reflow soldering.
- * High reliability and easy surface mount assembly.
- * Wide range of inductance values are available for flexible needs.

PART NUMBER

LPI 0603 F T 1R0 J - □□

1 2 3 4 5 Internal Code

Taping

1 Product Type

2 Chip Dimension

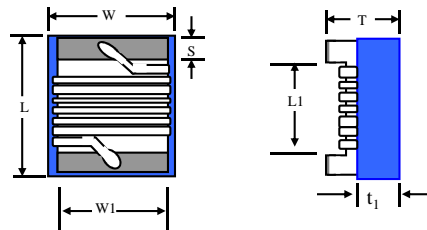

Size (inch) mm	Length (L) (inch) mm	Width (W) (inch) mm	Thickness (T) (inch) mm	Terminal (S) (inch) mm	L1 (Ref.) mm	W1 (Ref.) mm	(t ₁) (Ref.) mm
0603 1608	(0.063 ± 0.008) 1.60 ± 0.20	(0.041 ± 0.008) 1.05 ± 0.20	(0.041 ± 0.004) 1.05 ± 0.10	(0.014 ± 0.004) 0.35 ± 0.10	0.80	0.95	0.50
0805 2012	(0.080 ± 0.008) 2.00 ± 0.20	(0.050 ± 0.008) 1.25 ± 0.20	(0.047 max.) (1.20 max.)	(0.016 ± 0.004) 0.40 ± 0.10	1.20	1.20	0.60
1210 3225	(0.126 ± 0.008) 3.20 ± 0.20	(0.098 ± 0.008) 2.50 ± 0.20	(0.047 max.) (1.20 max.)	(0.020 ± 0.004) 0.50 ± 0.10	2.20	2.40	0.80

3 Material Type

F : Ferrite Material

4 Inductance Value

1R0 = 1.0 uH

100 = 10 uH

5 Tolerance

K = ± 10 % M = ± 20 %

CHIP INDUCTOR SPECIFICATIONS

1 Scope

This specification applies to miniature wire wound inductors for power line of the following types used in electronics equipment :

2 Construction

*Configuration

& Dimension : Please refer to the attached figures and tables.

*Terminals : LPI series terminals shall consist of PdAg alloy followed by Nickel, then solder plating for easier soldering.

3 Operating Temperature Range

Operating Temperature Range is the scope of ambient temperature at which the inductor can be operated continuously at rated current.

*Temp. Range : Ferrite Material : - 40°C to + 85°C

4 Ingredient of terminals electrode.

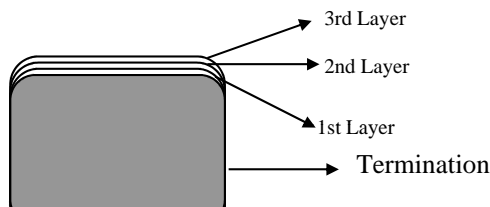

- a) 1st layer : Ag/Pd
- b) 2nd layer : Nickel
- c) 3rd layer : Sn

5 Characteristics

Standard Atmospheric Conditions

Unless otherwise specified, the standard range of atmospheric conditions for making measurements and tests are as follows :

*Ambient Temperature : 25 °C ± 2 °C

*Relative Humidity : 60% to 70%

*Air Pressure : 86 Kpa to 106 Kpa

CHIP INDUCTOR SPECIFICATIONS

TEMPERATURE PROFILE

a Reflow temperature profile

(Temperature of the mounted parts surface on the printed circuit board)

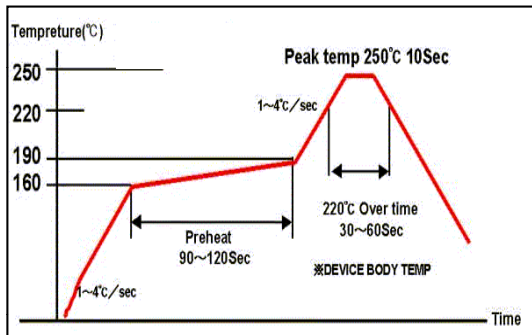

Recommended Peak Temperature: 250°C Max

250°C up /within 10secs

Max. Reflow temperature : 260°C.

Gradient of temperature rise: av 1-4°C/sec

Preheat: 160-190°C/within 90-120secs

220°C up /within 30-60secs

Composition of solder Sn-3Ag-0.5Cu

b Dip temperature

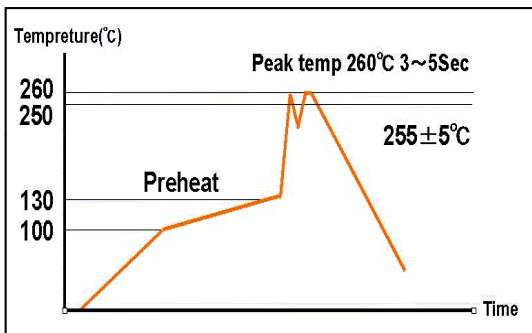

Solder bathtub temperature: 260°C max within 5secs.

Preheating temperature: 100~130°C

deposit solder temperature.

Composition of solder Sn-3Ag-0.5Cu

c Soldering iron tip temperature : 350°C max / within 3 seconds.

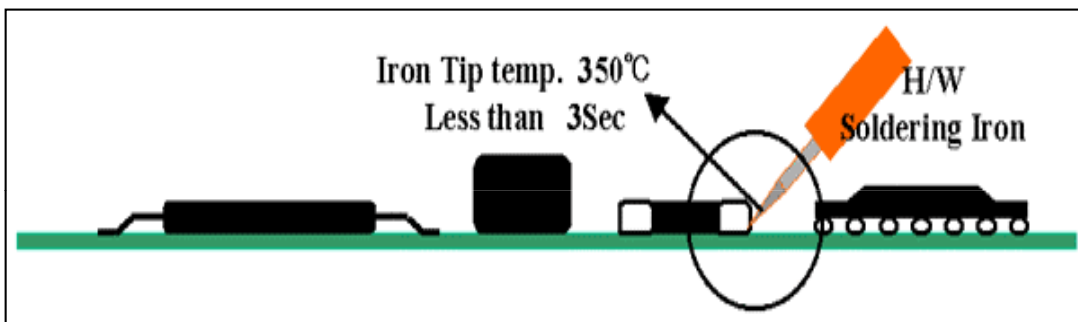

WIRE WOUND CHIP INDUCTOR

LPI 0805 (2012) SERIES

Part No.	Inductance ¹ (uH)	Percent Tolerance	Q ² Min	S.R.F. ³ Min (MHz)	RDC ⁴ Max (Ω)	Isat ⁵ Max (mA)	Idc ⁶ Max (mA)	
LPI 0805 FT 1R0 □-□□	1.0 @ 100 KHz	K, M	10 @	1 MHz	400	0.35	800	750
LPI 0805 FT 1R2 □-□□	1.2 @ 100 KHz	K, M	10 @	1 MHz	350	0.40	750	700
LPI 0805 FT 1R5 □-□□	1.5 @ 100 KHz	K, M	10 @	1 MHz	300	0.45	720	680
LPI 0805 FT 1R8 □-□□	1.8 @ 100 KHz	K, M	10 @	1 MHz	250	0.60	680	650
LPI 0805 FT 2R2 □-□□	2.2 @ 100 KHz	K, M	10 @	1 MHz	180	0.65	650	630
LPI 0805 FT 2R7 □-□□	2.7 @ 100 KHz	K, M	10 @	1 MHz	120	0.75	630	600
LPI 0805 FT 3R3 □-□□	3.3 @ 100 KHz	K, M	10 @	1 MHz	90	0.85	600	570
LPI 0805 FT 3R9 □-□□	3.9 @ 100 KHz	K, M	10 @	1 MHz	80	0.90	550	500
LPI 0805 FT 4R7 □-□□	4.7 @ 100 KHz	K, M	10 @	1 MHz	70	1.10	450	430
LPI 0805 FT 5R6 □-□□	5.6 @ 100 KHz	K, M	10 @	1 MHz	60	1.25	430	400
LPI 0805 FT 6R8 □-□□	6.8 @ 100 KHz	K, M	10 @	1 MHz	50	1.35	380	360
LPI 0805 FT 8R2 □-□□	8.2 @ 100 KHz	K, M	10 @	1 MHz	45	1.50	360	340
LPI 0805 FT 100 □-□□	10 @ 100 KHz	K, M	10 @	1 MHz	40	2.00	340	310
LPI 0805 FT 150 □-□□	15 @ 100 KHz	K, M	10 @	1 MHz	30	2.50	300	180
LPI 0805 FT 180 □-□□	18 @ 100 KHz	K, M	10 @	1 MHz	25	2.90	250	170
LPI 0805 FT 220 □-□□	22 @ 100 KHz	K, M	10 @	1 MHz	20	3.20	200	150

1. Inductance is measured in HP-4284A /4285A RF LCR meter with SMD-A fixture.

2. Q is measured in HP-4284A / 4285A RF LCR meter with SMD-A fixture.

3. SRF is measured in ENA E5071B network analyzer

4. RDC is measured in HP-4338B milliohmeter.

5. Inductance drop 10% from the initial value.

6. For 25 °C Rise.

Unit weight = 0.0084g (for ref.)

LPI 0805 (2012) SERIES

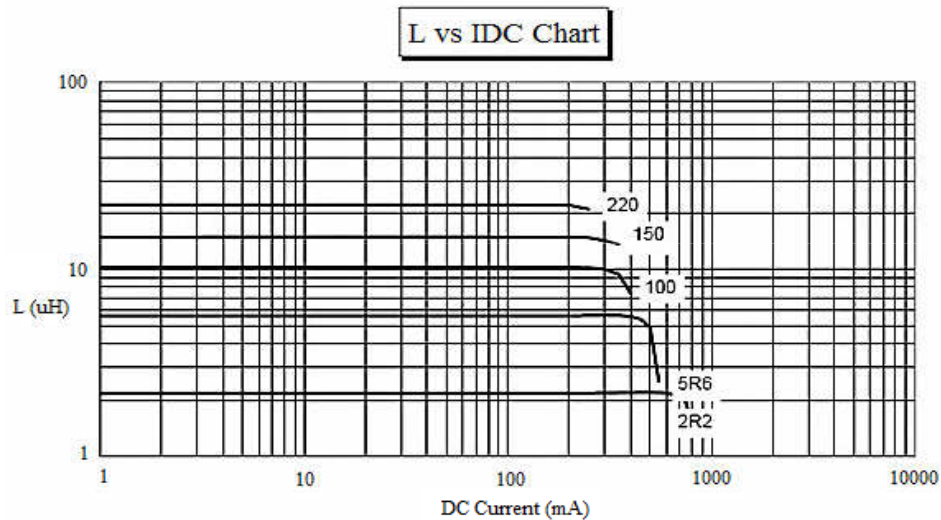

SPECIFICATION

	ITEM	CONDITION	SPECIFICATION
Mechanical Characteristics	Inductance and Tolerance	Measuring Frequency : As shown in Product Table	Within Specified Tolerance
	Quality Factor	Measuring Temperature : + 25 °C	
	Insulation Resistance	Measured at 100V DC between inductor terminals and center of case.	1000 mega ohms minimum
	Dielectric Withstanding Voltage	Measured at 500V AC between inductor terminals and center of case for a maximum of 1 minute.	No damage occurs when the test voltage is applied.
	Temperature Coefficient of Inductance (TCL)	Over - 40 °C to + 85°C at frequency specified in Product Table.	+ 25 to 500 ppm / °C TCL = $\frac{L1 - L2}{L1(T1-T2)} \times 10^6$ (ppm /°C)
	Electrical Characteristics	Component Adhesion (Push Test)	The component shall be reflow soldered onto a P. C. Board (240 °C ± 5°C for 20 seconds). Then a dynamometer force gauge shall be applied to any side of the component.
Drop Test		The inductor shall be dropped two times on the concrete floor or the vinyl tile from 1M naturally.	Change In Inductance: No more than 5%
Thermal Shock Test		Each cycle shall consist of 30 minutes at -40 °C followed by 30 minutes at +85 °C with a 20-second maximum transition time between temperature extremes. Test duration is 10 cycles.	Change In Q: No more than 10% Change In Appearance: Without distinct damage

SPECIFICATION

	ITEM	CONDITION	SPECIFICATION
Endurance Characteristics	Solderability	Dip pads in flux and dip in solder pot containing lead free solder at $240\text{ }^{\circ}\text{C} \pm 5^{\circ}\text{C}$ for 5 seconds.	A minimum of 80% of the metalized area must be covered with solder.
	Resistance to Soldering Heat	Dip the components into flux and dip into solder pot containing lead free solder at $260\text{ }^{\circ}\text{C} \pm 5\text{ }^{\circ}\text{C}$ for 5 ± 2 seconds.	Change In Inductance: No more than 5%
	Vibration (Random)	Inductors shall be randomly vibrated at amplitude of 1.5mm and frequency of 10 - 55 Hz: 0.04 G / Hz for a minimum of 15 minutes per axis for each of the three axes.	Change In Q: No more than 10%
	Cold Temperature Storage	Inductors shall be stored at temperature of $-40\text{ }^{\circ}\text{C} \pm 2\text{ }^{\circ}\text{C}$ for 1000hrs (+ 48 -0 hrs.) Then inductors shall be subjected to standard atmospheric conditions for 1 hour. After that, measurement shall be made.	Change In Appearance : Without distinct damage
	High Temperature Storage	Inductors shall be stored at temperature of $85\text{ }^{\circ}\text{C} \pm 2\text{ }^{\circ}\text{C}$ for 1000hrs (+48 - 0hrs.) Then inductors shall be subjected to standard atmospheric conditions for 1 hour. After that, measurement shall be made.	
	Moisture Resistance	Inductors shall be stored in the chamber at $45\text{ }^{\circ}\text{C}$ at 90 - 95 R. H. for 1000 hours. Then inductors are to be tested after 2 hours at room temperature.	Inductors shall not have a shorted or open winding.
	High Temperature with Loaded	Inductors shall be stored in the chamber at $+85\text{ }^{\circ}\text{C}$ for 1000 hours with rated current applied. Inductors shall be tested at the beginning of test at 500 hours and 1000 hours. Then inductors are to be tested after 1 hour at room temperature.	

PACKAGING INFORMATION

Packing Quantity

Type	Pcs / Reel
LPI0603	3,000
LPI0805	2,000
LPI1210	2,000

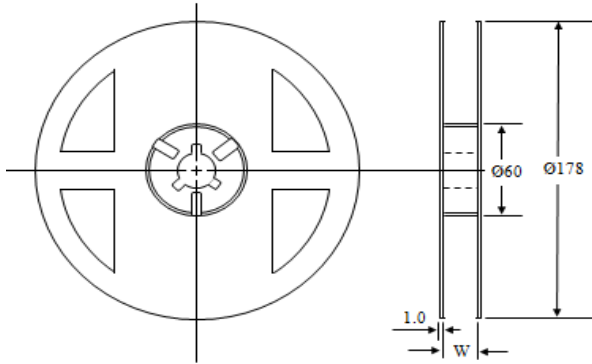

Dimensions (unit: m/m)

Type	Chip Cavity		Insert Pitch F	Tape Thickness		
	A	B		K	T	W
LPI0603	1.40	1.90	4.00	1.15	0.22	8.00
LPI0805	1.50	2.35	4.00	1.45	0.22	8.00
LPI1210	2.69	3.56	4.00	1.42	0.22	8.00

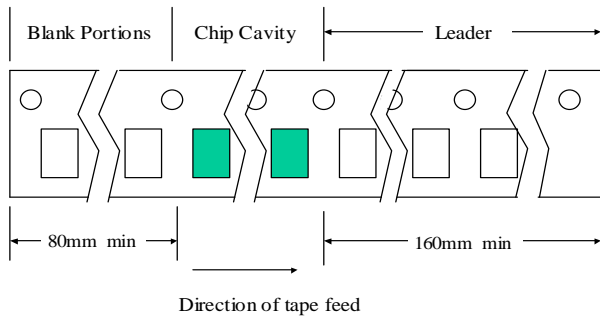
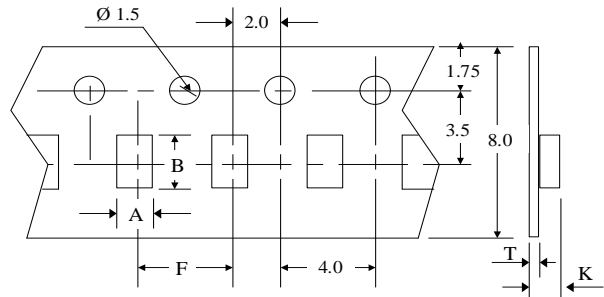

Top Tape Strength

The top tape requires a peel-off force of 0.2 to 0.7N in the direction of the arrow as illustrated below.

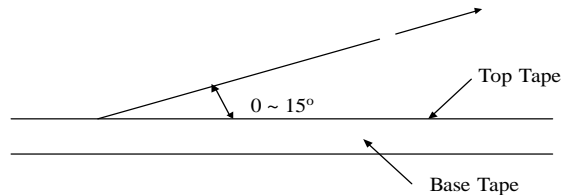

Dimensions (unit : m/m)

TYPE	A	B	C
LPI0603	1.90	0.65	1.20
LPI0805	2.60	0.75	1.40
LPI1210	4.00	1.70	2.82

Recommended Pattern

