

POWER INDUCTOR MOLDING TYPE CIP SERIES

INTRODUCTION

The CIP series power inductors are surface-mount molding type which widely used in the applications such as DC/DC converters in Notebook, Netbook, desktop and server and low profile, high current power supplies.

FEATURES

- * Operating temperature -55 to +125 °C.
- * High performance (saturation current) due to powdered iron composition.
- * Low loss due to design of low DC resistance.
- * Frequency application up to 3MHz.
- * Low profile with max thickness 3.0mm.
- * 100% lead free and metted RoHS standard.
- * Excellent solderability and resistance to soldering heat .
- * Suitable for reflow soldering.
- * High reliability and easy surface mount assembly.

PART NUMBER

CIP	0630	LR	1R0	M	-	□□
1	2	3	4	5	Internal Code	

1 Product Type

2 Dimension

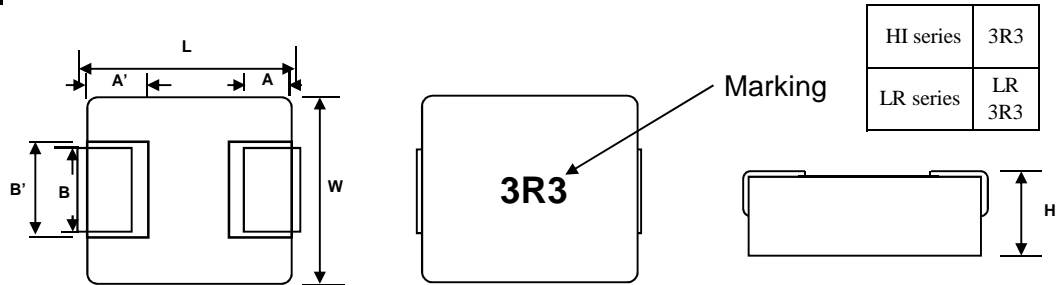

SIZE	L (mm)	W (mm)	H (mm)	A (mm)	A' (mm)	B (mm)	B' (mm)
CIP0520	5.60 ± 0.35	5.20 ± 0.20	2.00 ± 0.10	1.0 ± 0.4	1.5 ± 0.1	2.0 ± 0.3	2.5 ± 0.2
CIP0530	5.60 ± 0.35	5.20 ± 0.20	3.00 max.	1.0 ± 0.4	1.5 ± 0.1	2.0 ± 0.3	2.5 ± 0.2
CIP0630	7.20 ± 0.30	6.65 ± 0.20	3.00 max.	1.6 ± 0.4	2.0 ± 0.1	3.0 ± 0.3	3.4 ± 0.2

3 Application

HI : High Saturation Current
LR : Low DC Resistance

4 Inductance Value

1R0 = 1.0μH 2R2 = 2.2μH
1R5 = 1.5μH 3R3 = 3.3μH

5 Tolerance

M = ± 20 %
N = ± 30 %

MOLDING TYPE INDUCTOR SPECIFICATION

1 Scope

This specification applies to fixed inductors of the following types used in electronic equipment :

- LR Type : For low power application with lower DC resistance and lower power loss design requirement.
- HI Type : For higher high performance application with higher saturation current requirement.

2 Construction

- Configuration & Dimension : Please refer to the attached figures and tables.

3 Operating Temperature Range

Operating Temperature Range is the scope of ambient temperature at which the inductor can be operated continuously at rated current.

- Temp. Range : - 55^oC to + 125^oC

4 Characteristics

Standard Atmospheric Conditions

Unless otherwise specified, the standard range of atmospheric conditions for making measurements and tests are as follows :

- Ambient Temperature : 25 °C ± 2 °C
- Relative Humidity : 60% to 70%
- Air Pressure : 86 Kpa to 106 Kpa

MOLDING TYPE INDUCTOR SPECIFICATION

Recommended Soldering Conditions (Please use this product by reflow soldering)

a Recommended Reflow temperature profile

(Temperature of the mounted parts surface on the printed circuit board)

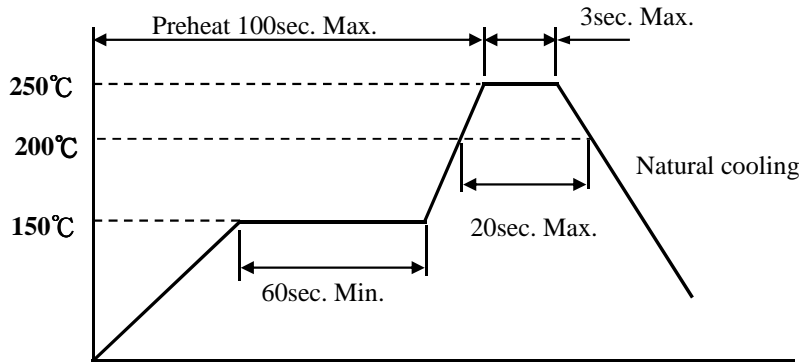

b Dip temperature

Use a solder iron of less than 30W when soldering, do not allow the soldering iron tip directly touch the ferrite body outside of terminal electrode.

2 seconds max. at 260°C.

c Recommended Footprint

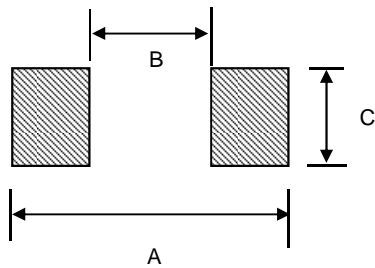

TYPE	A (mm)	B (mm)	C (mm)
0520	5.99	2.20	2.50
0530	5.99	2.20	2.50
0630	8.40	3.70	3.40

CIP0630 LR SERIES

Part No.	Inductance ¹ (uH)	Percent ² Tolerance	DCR ³		Isat ⁴ (A)	Irat ⁵ (A)
			Typ.(mΩ)	Max.(mΩ)		
CIP0630 LR R47 □-□□	0.47	M	3.5	4.1	20.0	16.5
CIP0630 LR R56 □-□□	0.56	M	4.7	5.0	18.0	15.5
CIP0630 LR R68 □-□□	0.68	M	6.0	6.5	17.0	14.0
CIP0630 LR R82 □-□□	0.82	M	7.0	7.5	16.0	12.5
CIP0630 LR 1R0 □-□□	1.0	M	8.5	9.0	15.0	12.0
CIP0630 LR 1R5 □-□□	1.5	M	10.5	12.0	14.0	10.0
CIP0630 LR 2R2 □-□□	2.2	M	16.0	18.5	10.0	8.0
CIP0630 LR 3R3 □-□□	3.3	M	25.0	28.0	10.0	6.5
CIP0630 LR 4R7 □-□□	4.7	M	32.5	35.0	6.5	5.5
CIP0630 LR 5R6 □-□□	5.6	M	32.5	35.5	5.0	6.0
CIP0630 LR 6R8 □-□□	6.8	M	54.0	60.0	6.0	4.5
CIP0630 LR 100 □-□□	10	M	62.0	68.0	5.5	4.0
CIP0630 LR 150 □-□□	15	M	110.0	120.0	5.0	3.0
CIP0630 LR 220 □-□□	22	M	152.0	167.0	2.5	2.5

1. Inductance is measured in HP-4284A Precision LCR Meter under 0.25V 100kHz.
2. Tolerance : M =20% , N=30%.
3. RDC is measured in HP 4338B mill ohm meter.(or equivalent).
4. Isat : Based on inductance change ($\Delta L/L_0$: LR -30% typical / HI -20% typical)
5. Irat : Based on temperature rise (ΔT : 40°C TYP.)

CIP0630 LR SERIES

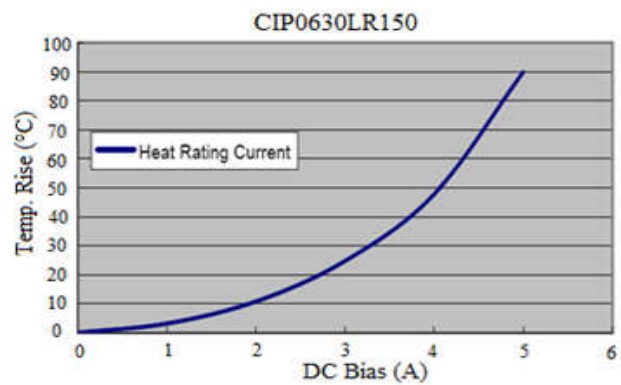
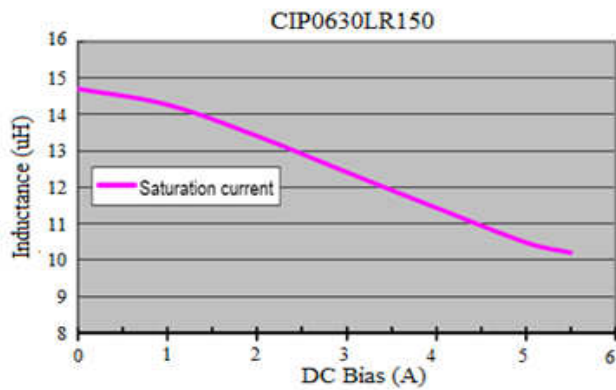

CIP0630 LR SERIES

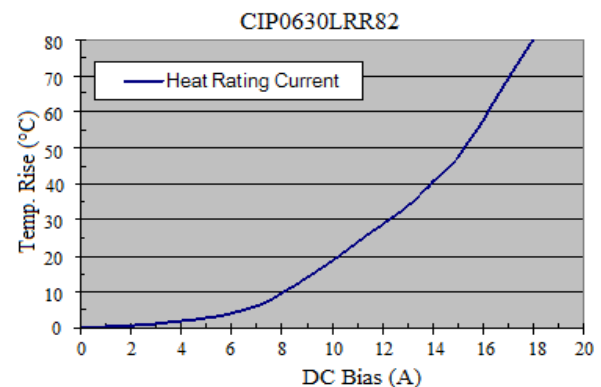
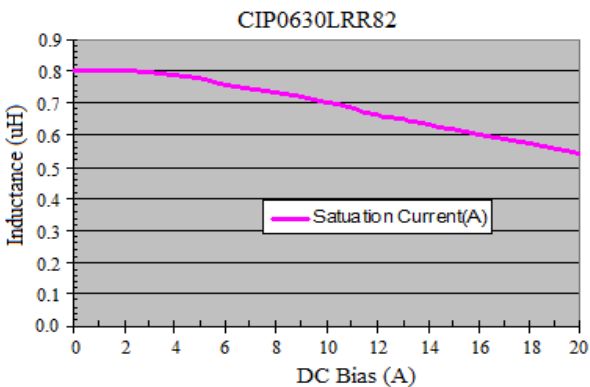
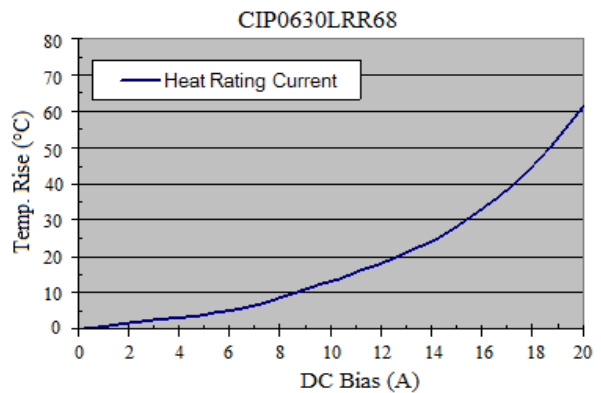
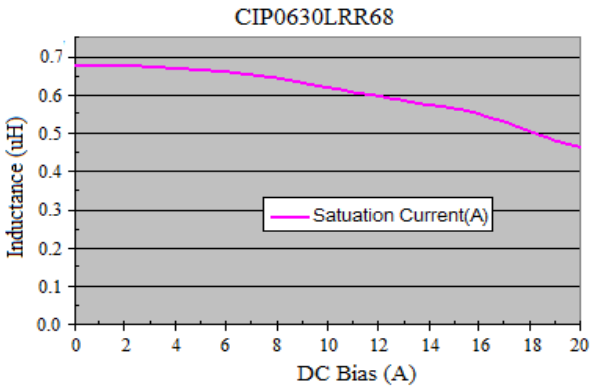
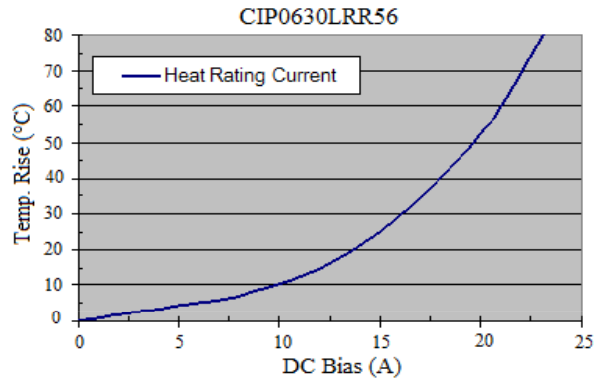
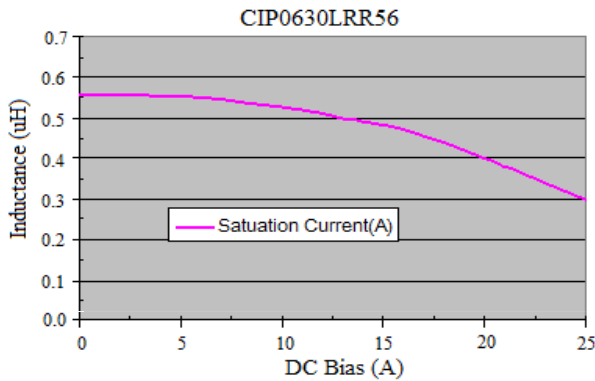
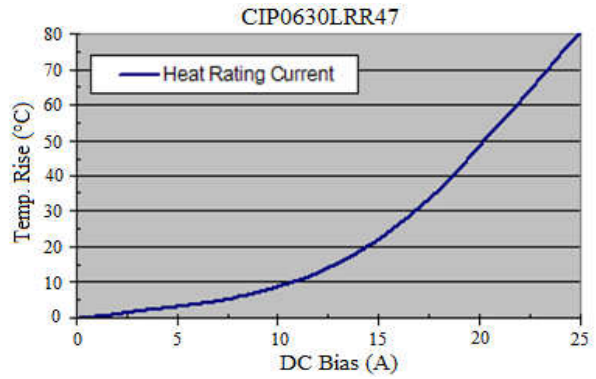
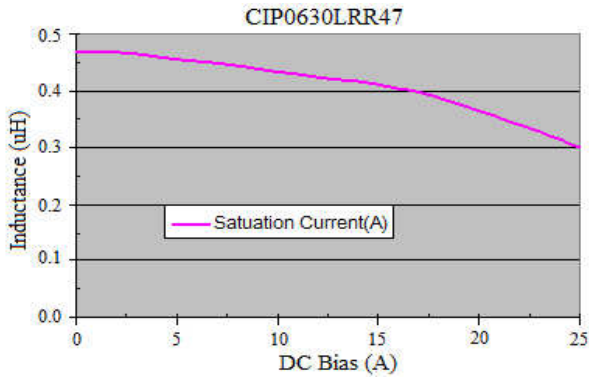

CIP0630 LR SERIES

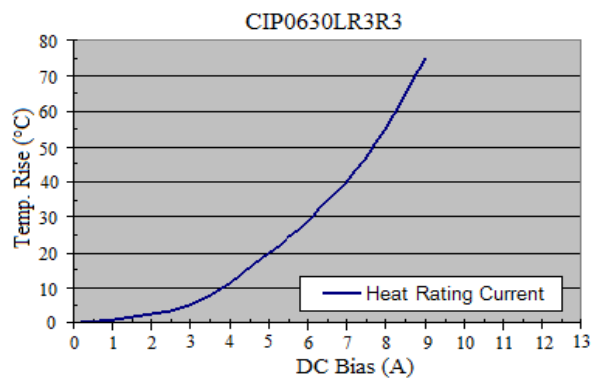
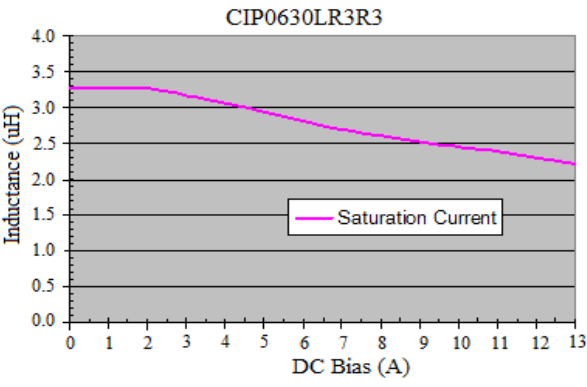
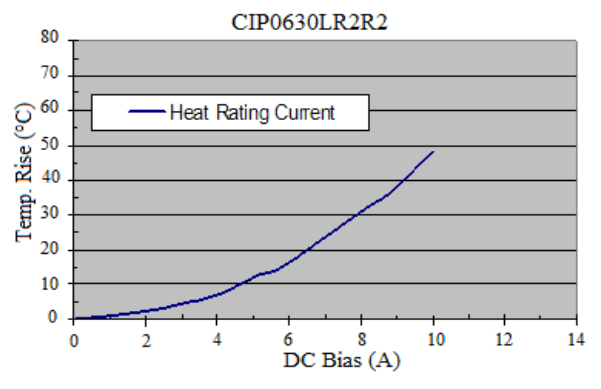
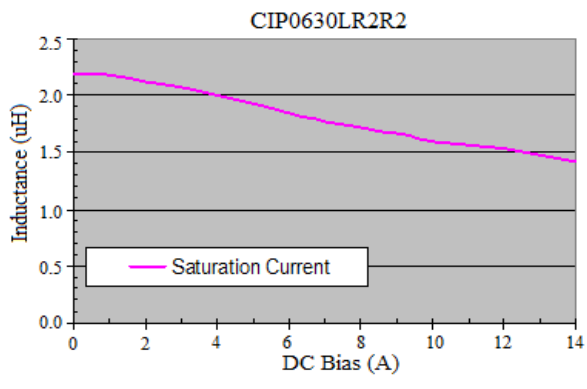
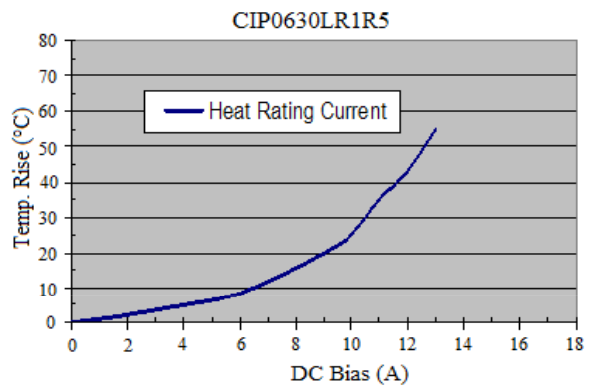
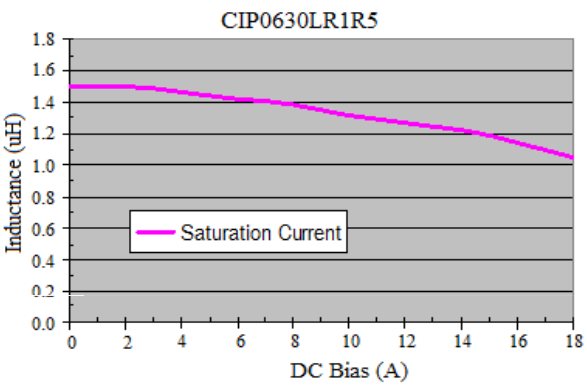
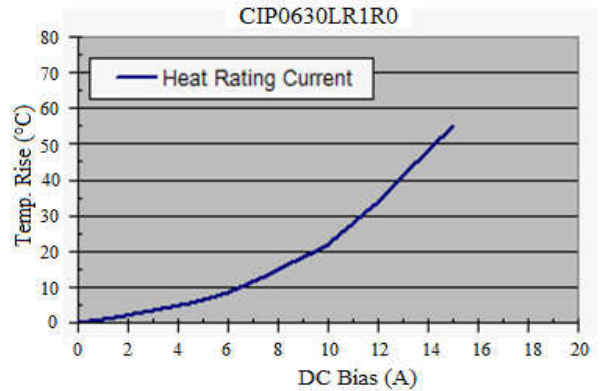
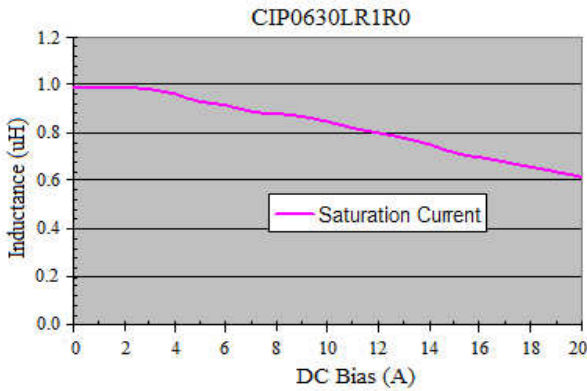

CIP0630 LR SERIES

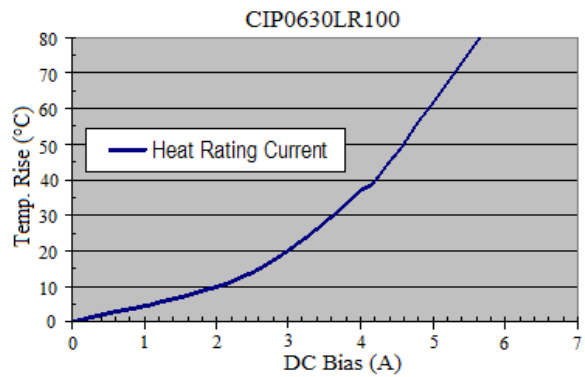
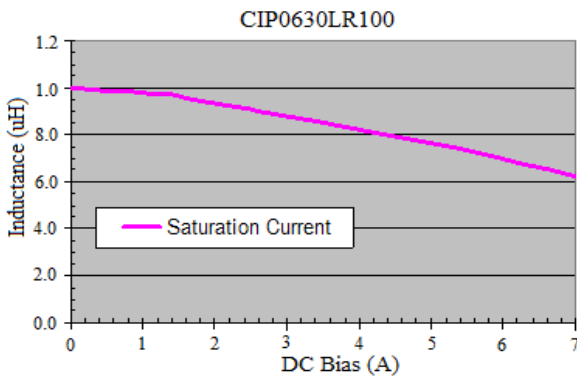
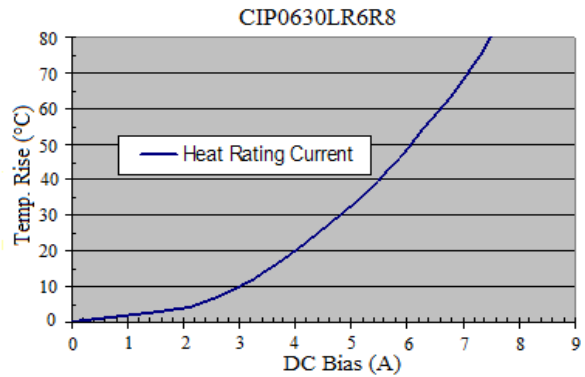
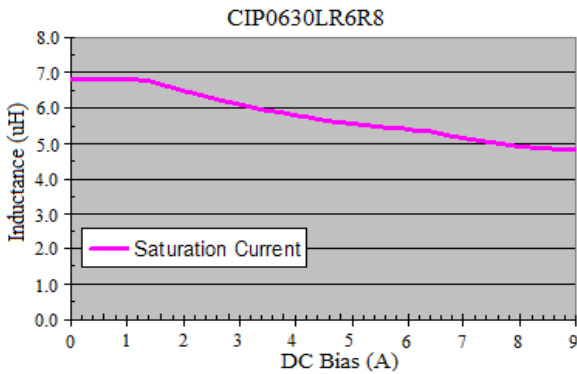
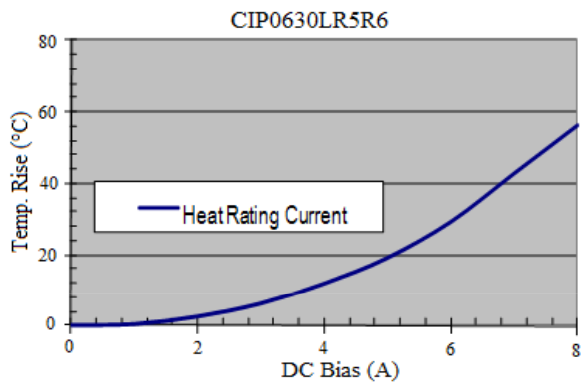
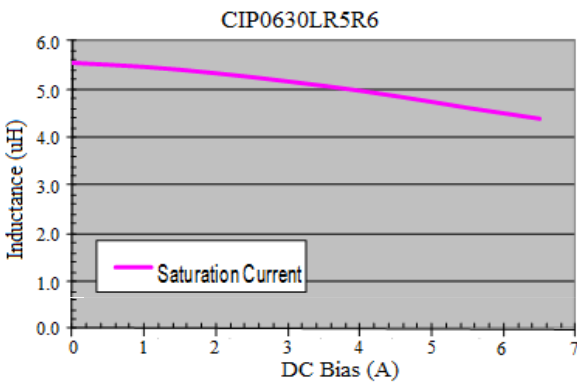
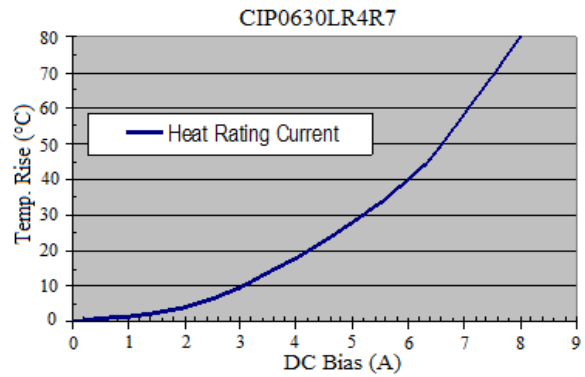
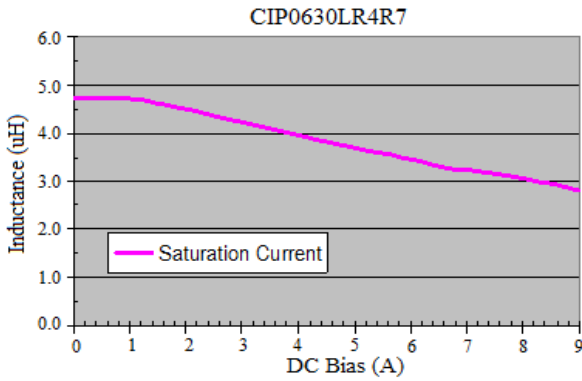

RELIABILITY SPECIFICATION

ITEM	SPECIFICATION	TEST CONDITION
Solderability	The metalized area must have 95% minimum solder coverage.	1. Preheating at 160±10°C 90sec 2. 245°C ±5°C for 2 ±1sec
Substrate Bending	$\Delta L/L_0 : \leq \pm 5\%$ There shall be no mechanical damage or electrical damage.	The sample shall be soldered onto the printed circuit board and a load applied until the figure in the arrow direction is made approximately 2mm(keep time 5±1 seconds) <div style="text-align: center;"> <p style="text-align: center;">F(Pressurization)</p> <p style="text-align: center;">PRESSURE ROD</p> </div>
Vibration	$\Delta L/L_0 : \leq \pm 5\%$ There shall be no mechanical damage	Solder specimen inductor on the test printed circuit board. Apply vibrations in each of the x,y and z directions for 2 house for a total of 6 hours. Frequency : 10~55~10Hz in 60sec as a period Amplitude : 1.5mm
High Temperature Storage	$\Delta L/L_0 : \leq \pm 5\%$ There shall be no mechanical damage or electrical damage.	The sample shall be left for 96 hours in an atmosphere with a temperature of 85±2°C and a normal humidity. Upon the measurement shall be made after the sample has been left in a normal temperature and normal humidity for 1 hour.
Low Temperature Storage	$\Delta L/L_0 : \leq \pm 5\%$ There shall be no mechanical damage or electrical damage.	The sample shall be left for 96 hours in an atmosphere with a temperature of -40±2°C. Upon completion of the test, the measurement shall be made after the sample has been left in a normal temperature and normal humidity for 1 hour.
Thermal Shock	$\Delta L/L_0 : \leq \pm 5\%$ There shall be no damage problems.	The sample shall be subject to 10 continuous cycles, such as shown in the following temperature cycle: <div style="text-align: center;"> </div> Measure the test items after leaving the inductors at room temperature and humidity for 1 hours.
Moisuture Storage	$\Delta L/L_0 : \leq \pm 5\%$ There shall be no mechanical damage.	The sample shall be left for 96 hours in a temperature of 60±2°C and a humidity(RH) of 90~95%. Upon completion of the test, the measurement shall be made after the sample has been left in a normal temperature and normal humidity more than 1 hour.

PACKAGING INFORMATION

The packaging must be done not to receive any damage during transporting and storing.

1. Tape dimensions

* CIP0520 / 0530 / 0630 SERIES

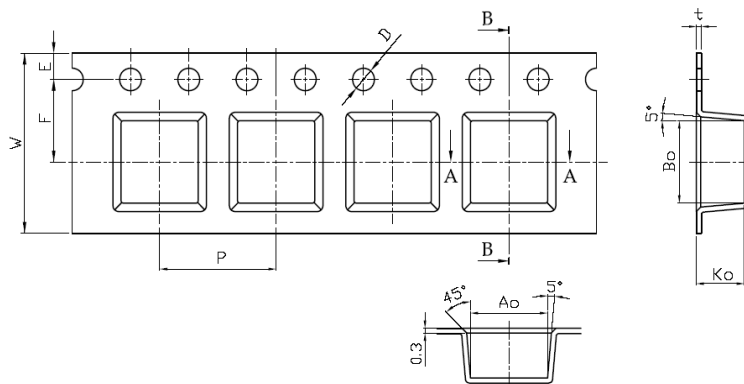

(Unit:m/m)

	0520	0530	0630
A0	5.30	5.30	7.20
B0	5.50	5.50	7.50
K0	2.20	3.30	3.60
P	8.00	8.00	12.00
t	0.40	0.40	0.30
W	12.00	12.00	16.00
E	1.75	1.75	1.75
F	5.50	5.50	7.50
D	1.50	1.50	1.50

2. Reel dimensions

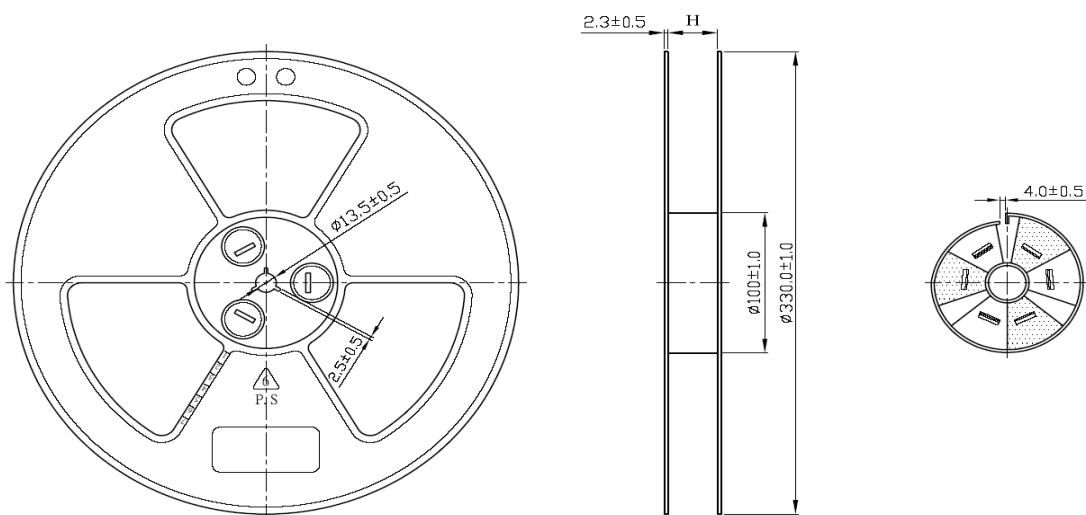

PACKAGING INFORMATION

3. Tapping figure

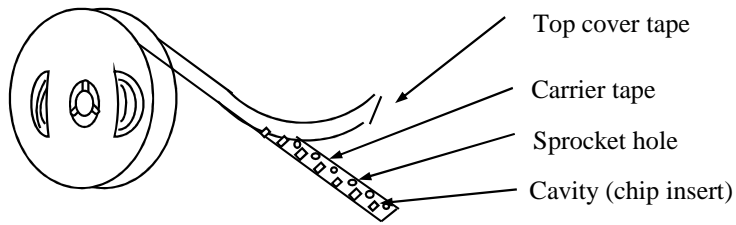

4. Packaging Form

There shall not continuation more than two vacancies of the product.

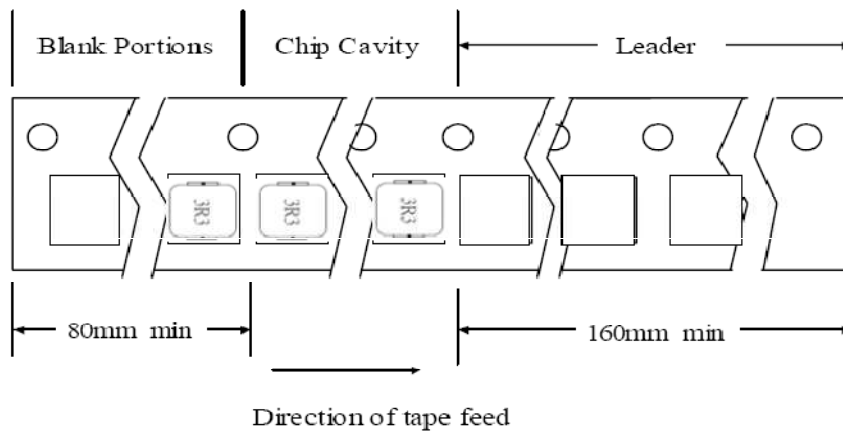

5. Packing Quantity

Reel Dimension (m/m) = ϕ 330	0520 series	0530 series	0630 series
Part per Reel (pcs)	2000	2000	1500
Inner Carton	4 Reels	4 Reels	4 Reels
Master Carton (pcs)	32000	32000	24000